

Laser Analyzing Telescope

Innovative Optical Laser Measurement Telescope for Angular Analysis

- Analyzes angular directions and collimation of light beams and lasers.
- Versatile – Measures Profile, Power, Angular Position and multiple laser beams in parallel.
- Complete test station with built-in Filter Slider.
- Extremely accurate.
- Built-in Pan\Tilt Mechanics.
- Excellent for bore-sighting between several parallax lasers .

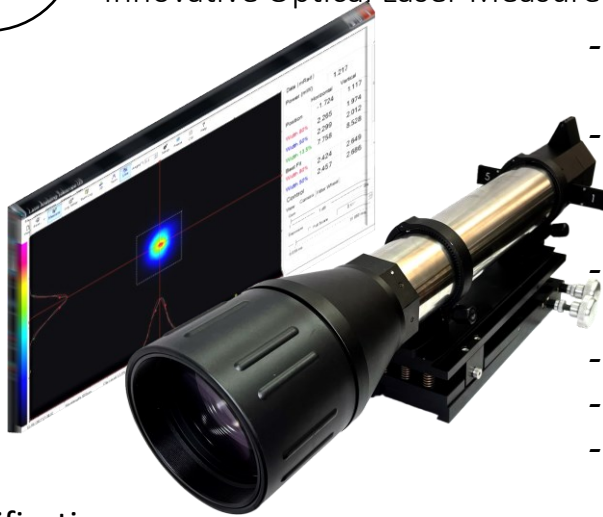

Specifications

Laser Type	CW & Pulsed
FoV Telescope & Beam Profiler	20 mrad (H), 12 mrad (V)
Clear Aperture	100 mm
Beam Divergence Measurements	Down to 0.1 mRad or better
Min. Focusing Distance	Focused at Infinity
Built in coarse aiming Laser Pointer	638 nm power <1.0 mW Class 2 laser product, IEC60825-1
Beam width resolution	Better than 1 μ rad
Spectral Response	350 - 1150 nm (350-1600 nm available as a special order)
Resolution (H x V pixels)	1920 x 1200 sensor can be divided into multiple active areas, working in parallel for up to 400 sectors (NEW)
Gain Control	x24
Dynamic Range	60 dB , 12 bit
Exposure Speed	39 μ sec to 20 sec
Frame Rate	30 fps– up to 550 fps@ fast mode (NEW)

Beam divergence accuracy	$\pm 2\%$
Position resolution of laser beam	Better than 1.5 μ rad
Pixel Size	5.86 μ m x 5.86 μ m
Pixel Bit Depth	8/12 bits
Background Subtraction	User activated
Trigger	<ul style="list-style-type: none"> • BNC External Trigger • Internal Software • Hardware Falling or Rising Edge • Trigger Delay 0.015ms - 4.0 sec
Pan & Tilt knobs	Tilt $\pm 2^\circ$, Pan $\pm 2.5^\circ$
Power Requirements	~ 2 Watt (Via USB 3.0 interface)
Dimensions (L x W x H) in mm	615 x 184 x 197
Weight (typical)	6.5 kg including cable
Min. Hardware Requirements	CPU i3 1.6 GHz, 4 GB RAM Min. Resolution 1366 x 766
Interface	USB 3.0, Windows 7/8/10 (32 & 64 bit)
Operating Temperature	0° – 35° C

Ordering Information

Model LAT-U3: A camera for 350 – 1600 nm with built-in filter slider – ND8 (or IR Edge) ND64, ND200, ND1000, ND32000, USB 3.0 cable, application software on CD/Flash Card, carrying case.

DUMA OPTRONICS LTD.

Website: <http://www.dumaoptronics.com>

E-mail: sales@duma.co.il

January 2024



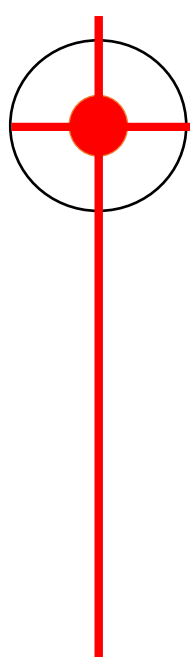

Laser Analyzing Telescope

Innovative Optical Laser Measurement Telescope for Angular Analysis

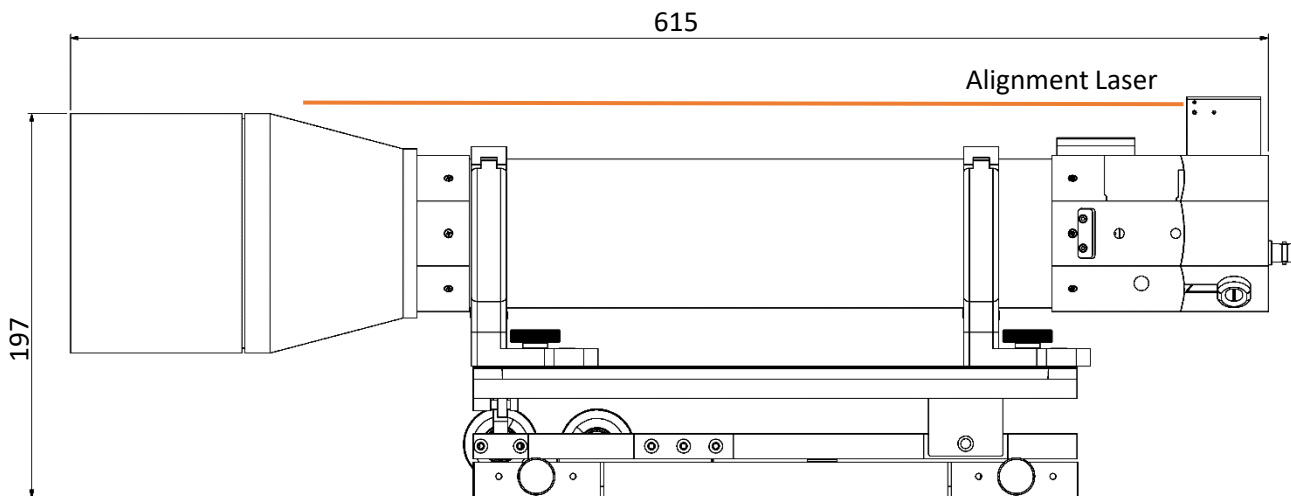
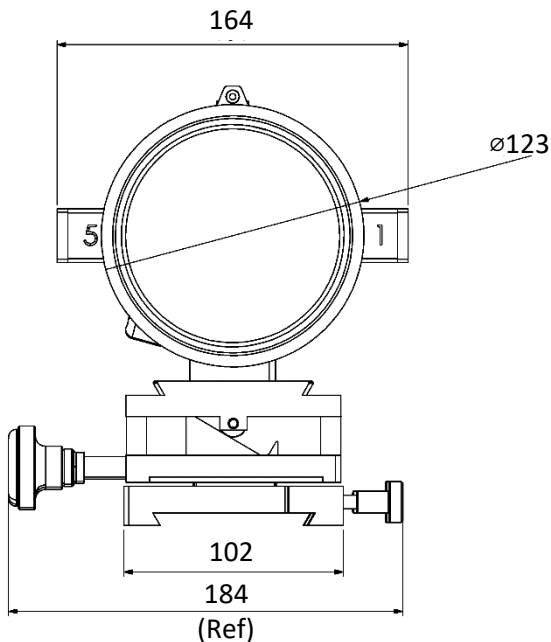

Dimensions are in mm.

DUMA OPTRONICS LTD.

Website: <http://www.dumaoptronics.com>

E-mail: sales@duma.co.il

January 2024

