

Wide FOV Electronic Autocollimator - E

UPGRADED

Extreme Resolution with Wide Field of View & multi beam analysis



- Precise USB3.0 device combining the functionality of autocollimator and alignment telescope.
- High resolution of down to 0.01 arc sec or 0.05 μ rad, with clear aperture exceeding 45 mm.
- Built-in computer controlled laser pointer for easy alignment.
- Built-in Pan & Tilt adjusting mechanics.

Specifications

FoV Autocollimator	$\pm 1^{\circ}10'$ (H) x $\pm 45'$ (V)
FoV Telescope & Beam Profiler	$\pm 2^{\circ}20'$ (H) x $\pm 1^{\circ}30'$ (V)
Clear Aperture	45 mm
Autocollimator's Resolution	0.01 sec
Autocollimator's Accuracy	1.0 sec
Light Source	LED- 650 nm Optional: 1060 nm, RGB. Special Order: 1310 nm
Retro-reflector for Alignment	$\varnothing 35$ mm, N.W 160 g, <5"
Min. Focusing Distance	Focused at Infinity
Built-in Coarse Aiming Laser Pointer	650 nm power <1.0 mW Class 2 laser product, IEC60825-1
Spectral Response	350 - 1310 nm (Telescope Mode)

Resolution (H x V pixels)	1920 x 1200 (Global Shutter) Can be divided into multiple working areas, in parallel for up to 400 sectors
Gain Control	x400
Dynamic Range	8/16 bit
Exposure Speed	39 μ sec to 2 sec
Frame Rate	40 fps (8 bit), 30 fps (16 bit) – up to 350 fps (AOI)
Pixel Size	5.86 μ m x 5.86 μ m
Background Subtraction	User activated
Front Accessory Thread	M72 x 0.75 mm
Trigger	Internal Software
Pan & Tilt Adjustment Range	Tilt $\pm 2^{\circ}$, Pan $\pm 2.5^{\circ}$
Power Requirements	~ 2 Watt (Via USB 3.0 interface)
Dimensions (L x W x H) in mm	222 x 92 x 158
Weight (typical)	3.8 kg
Min. Hardware Requirements	CPU i5 1.6 GHz, 4 GB RAM Min. Resolution 1366 x 766
Interface	USB 3.0, Windows 8/10/11 (32 & 64 bit)
Operating Temperature	10 $^{\circ}$ – 35 $^{\circ}$ C

Ordering Information

Model EAC-FOV-E: Complete system including a collimator unit with USB 3.0 camera, cable, retroreflector for infinity adjustment, application software on Flash Drive, carrying case.

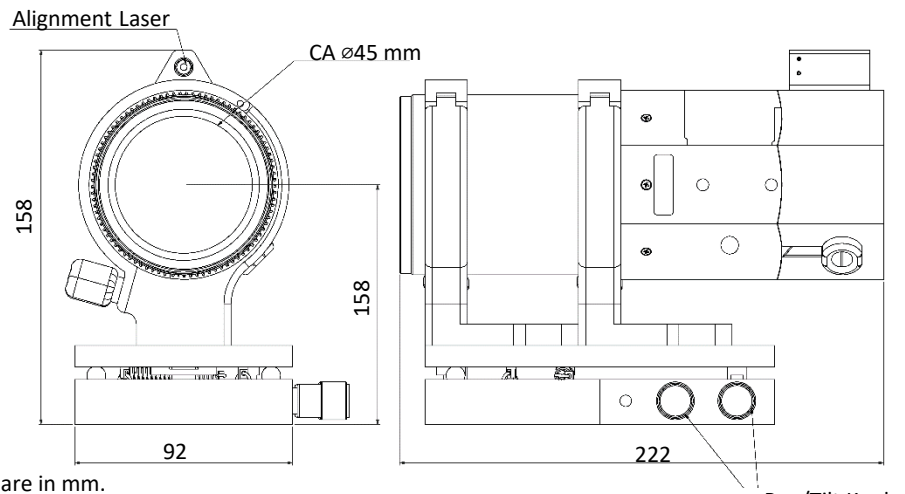

Dimensions are in mm.

DUMA OPTRONICS LTD.



Website: <http://www.dumaoptronics.com>

E-mail: sales@duma.co.il

July 2023